

THIS DRAWING IS UNPUBLISHED. RELEASED FOR PUBLICATION
 © COPYRIGHT BY TYCO ELECTRONICS CORPORATION. ALL RIGHTS RESERVED.

LOC	DIST	REVISIONS					
FT	0	P	LTR	DESCRIPTION	DATE	DWN	APVD
			01	REVISED PER ECO-05-7002	8/5/05	SS	SRY

MATERIALS:
 HOUSING: POLYAMIDE, UL94V-0.
 TERMINALS: COPPER ALLOY, TIN PLATED.
 SCREWS: STEEL, ZINC PLATED.

ELECTRICAL:
 RATING: 20A, 150V(300V LIMITED RATING)
 UL & CSA.

MECHANICAL:
 WIRE RANGE: 14-22 AWG.
 MAXIMUM TIGHTENING TORQUE: 7 IN-LBS.
 RUNNING TORQUE: 0.5-3.5 IN-LB.

⚠ PERMANENT WHITE INK.

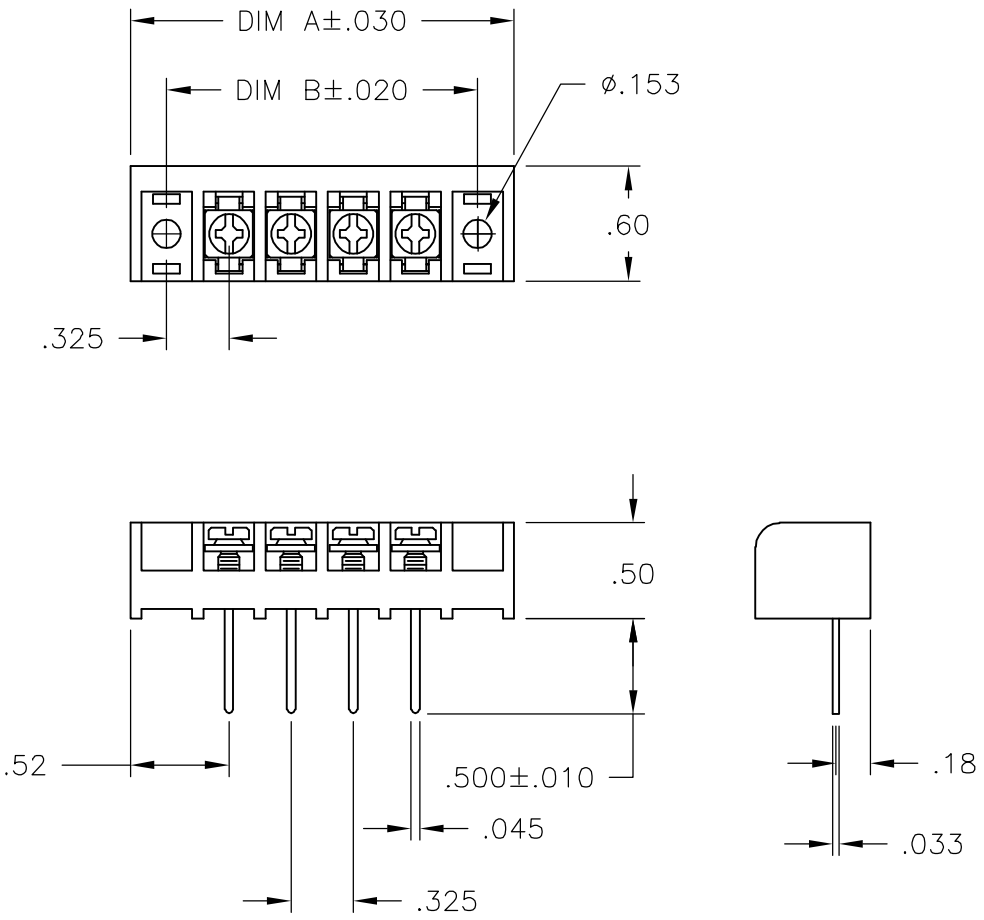

9.811	9.425	28	4WWV-28-006	2-796598-8
9.486	9.100	27	4WWV-27-006	2-796598-7
9.161	8.775	26	4WWV-26-006	2-796598-6
8.836	8.450	25	4WWV-25-006	2-796598-5
8.511	8.125	24	4WWV-24-006	2-796598-4
8.186	7.800	23	4WWV-23-006	2-796598-3
7.861	7.475	22	4WWV-22-006	2-796598-2
7.536	7.150	21	4WWV-21-006	2-796598-1
7.211	6.825	20	4WWV-20-006	2-1546158-0
6.886	6.500	19	4WWV-19-006	2-796598-0
6.561	6.175	18	4WWV-18-006	1-796598-9
6.236	5.850	17	4WWV-17-006	1-796598-8
5.911	5.525	16	4WWV-16-006	1-796598-7
5.586	5.200	15	4WWV-15-006	1-796598-6
5.261	4.875	14	4WWV-14-006	1-796598-5
4.936	4.550	13	4WWV-13-006	1-796598-4
4.611	4.225	12	4WWV-12-006	1-796988-5
4.286	3.900	11	4WWV-11-006	7-1437649-1
3.961	3.575	10	4WWV-10-006	1-796598-3
3.636	3.250	9	4WWV-09-006	1-796598-2
3.311	2.925	8	4WWV-08-442	6-1437649-7
3.311	2.925	8	4WWV-08-006	796598-2
2.986	2.600	7	4WWV-07-006	1-796598-1
2.661	2.275	6	4WWV-06-006	1-796598-0
2.336	1.950	5	4WWV-05-006	796598-9
2.011	1.625	4	4WWV-04-006	796598-8
1.686	1.300	3	4WWV-03-006	1-1546158-4
1.361	.975	2	4WWV-02-006	796598-7

SEE FIGURE

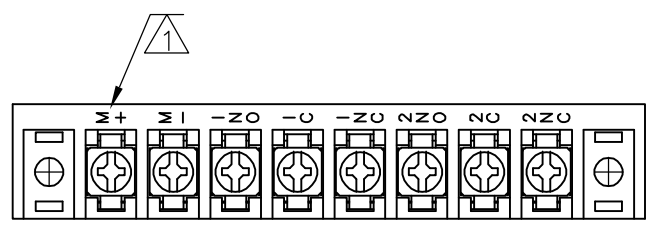

6-1437649-7

THIS DRAWING IS A CONTROLLED DOCUMENT.		DWN S SCHLEGEL 6/17/05	BUCHANAN Tyco Electronics Corporation Harrisburg, Pa 17105-3608	
DIMENSIONS: INCHES		CHK S.YODER 6/17/05		
TOLERANCES UNLESS OTHERWISE SPECIFIED:		APVD S. YODER 6/17/05	NAME 4WWV-XX-006 ASSEMBLY	
0 PLC ± - 1 PLC ± - 2 PLC ± .01 3 PLC ± .005 4 PLC ± - ANGLES ± 1'		PRODUCT SPEC -	APPLICATION SPEC -	
MATERIAL -		FINISH -	WEIGHT -	RESTRICTED TO -
		SIZE A3 CAGE CODE 00779 DRAWING NO C-7-1437649-1		
		CUSTOMER DRAWING		SCALE NTS SHEET 1 OF 1 REV 01